



Vidheksh
SLIDING HEAD SOLUTIONS

**CNC TURNING MACHINE
SPARES, TOOLS &
ACCESSORIES**

VIRAL MEHTA | 99796 86648

**C-131, SUMEL - 7, SONI NI CHALI, RAKHIYAL,
AHMEDABAD - 380023, GUJARAT**

URL : www.vidheksh.com

Email : solution@vidheksh.com

CNC
HOLDERS



INSERTS



CHUCK T-NUTS



TURRET HOLDERS



SOFT JAWS

BORING HOLDER SLEEVE



CNC TURNING MACHINE



Vidheksh
SLIDING HEAD SOLUTIONS

C-131, Safal Sumel -7, Soni Ni Chawl, Rakhiyal, Ahmedabad - 380023
99796 86648 | 98799 86648 | solution@vidheksh.com | www.vidheksh.com

SPHOORTI

Precision Assured



Product Range :-

- TOOL DISC (TURRET) VDI | BMT
- TOOL HOLDER - VDI | BMT
- DRIVEN TOOL HOLDERS - VDI | BMT
- VMC BT HOLDER
- VTP HOLDER

Vidheksh
SLIDING HEAD SOLUTIONS



ACCESSORIES FOR CNC & VMC MACHINE

BACK



HARDIK

CNC Automation

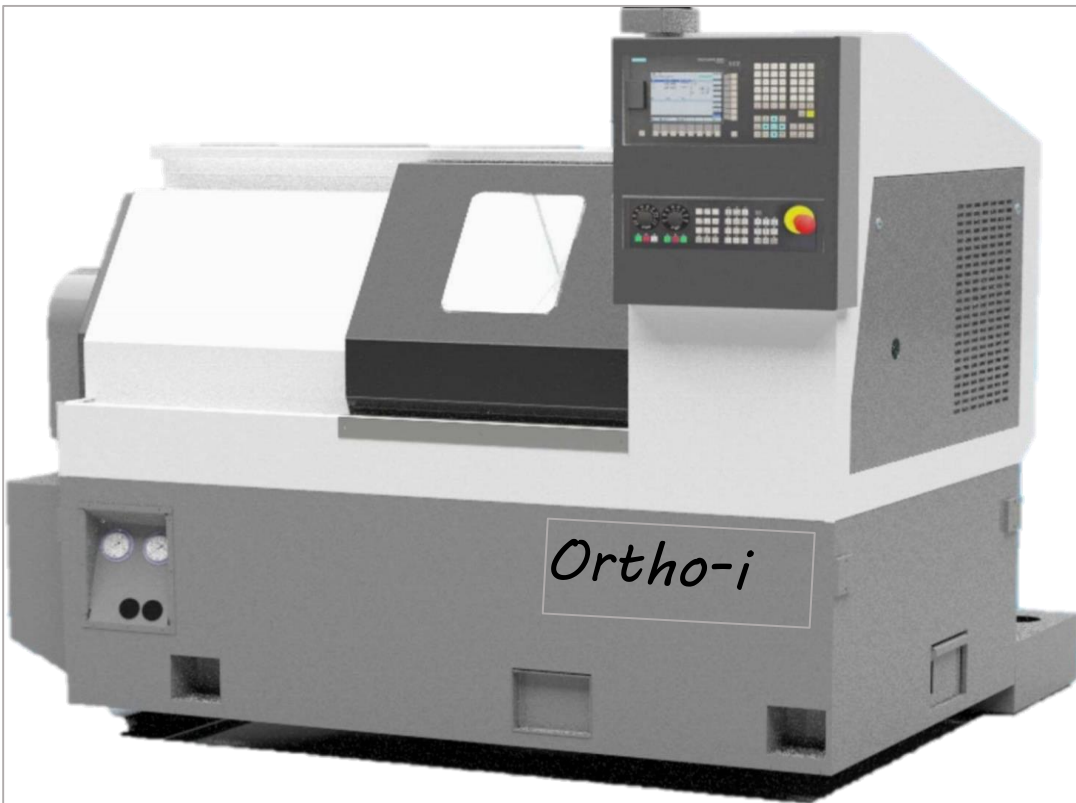

ORTHO i CNC MACHINE FOR SURGICAL SCREWS

- DELTA NC-200 CONTROLLER WITH QUICK, EASY AND SIMPLE PROGRAMMING TECHNIQUE..
- EFFORTLESS AND EASY CHANGE OVER AND SET UP.
- HEXAGONAL BROACHING CAN ALSO BE DONE.
- ROBUST AND RIGID MACHINE STRUCTURE.
- DEDICATED MACHINE FOR SURGICAL SCREWS MANUFACTURING.

Vidheksh
SLIDING HEAD SOLUTIONS



ORTHO i – CNC MACHINE

BACK





AUTOBITS



FEASIBILITY

- CNC Turning
- VMC Machine
- HMC Machine
- PLC Machine
- SPM Machine

- Production Report
- Tool Usage Report
- Downtime Analysis Report
- OEE Reports
- Alerts & Alarm Reports
- Custom Reports

Shift wise
 Daily
 Weekly
 Monthly
 Yearly
 Reports available

Vidheksh
 SLIDING HEAD SOLUTIONS



INDUSTRY 4.0 | Iot System

SMART- DIGITAL SUPERVISOR FOR CNC'S

BACK





Collets & Accessories



CNC COLLET CHUCK



BAR PULLER



TRAUB FINGERS



Vidheksh
SLIDING HEAD SOLUTIONS



CNC COLLETS & ACCESSORIES

BACK

Meson
Cutting Tools



Product Range :-

- CUSTOM DESIGN SC TOOL
- BROACHING TOOL
- DOVETAIL CUTTER
- SC DRILL, END MILL, BALL MILL CUTTER

Vidheksh
SLIDING HEAD SOLUTIONS



SOLID CARBIDE TOOLINGS

BACK



TOOLFAST

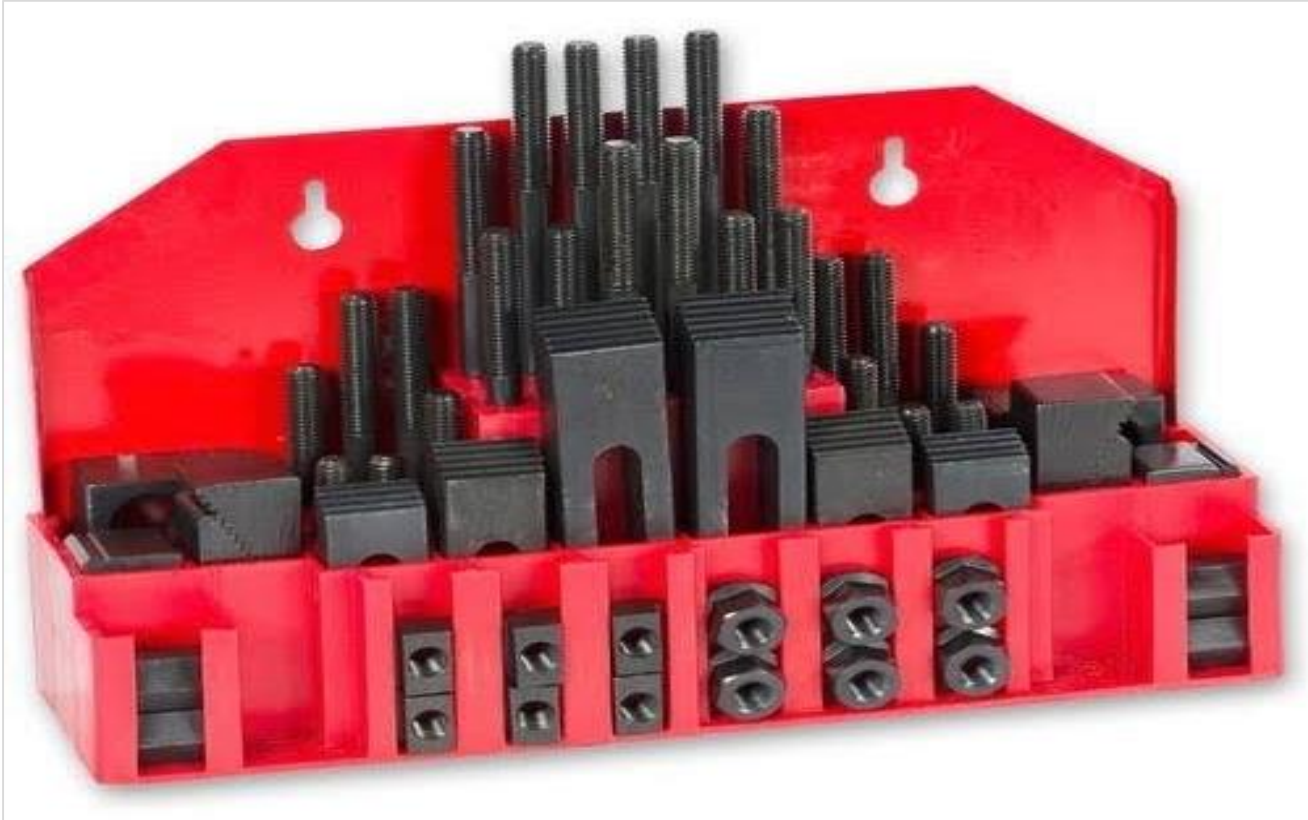

Product Range :-

- CLAMPS & CLAMPING ELEMENTS
- WIRE CUT EDM WORK HOLDERS
- MILLING & GRINDING ACCESSORIES
- PNEUMATIC & HYDRAULIC CLAMPS

Vidheksh
SLIDING HEAD SOLUTIONS



CLAMPING ACCESSORIES

BACK



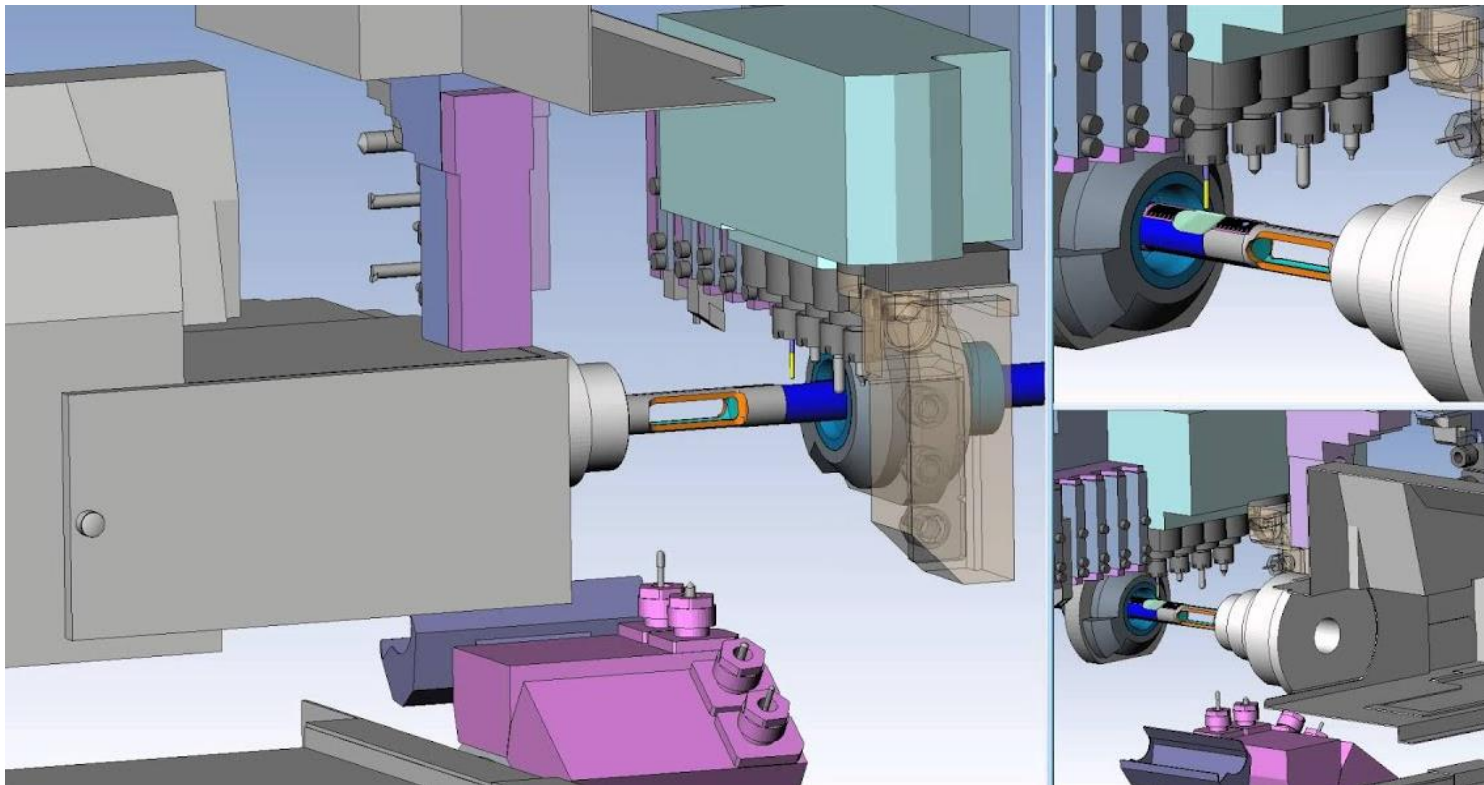

- 2-5 Axis Milling
- 2-22 axis Turning
- High Speed Machining
- Wire EDM
- Multitasking Machining

Vidheksh
SLIDING HEAD SOLUTIONS



CAM SOLUTION

Vidheksh Associate with



Authorized Value Added Reseller - Gujarat



radan

BACK



DIAMETAL

Swiss Cutting Tool



DIAMETAL

Group 



simply **D**ifferent

Product Range : -

- PARTING | GROOVING
- ISO TURNING INSERTS & HOLDERS
- SPECIAL DESIGN CARBIDE TOOLS

Vidheksh
SLIDING HEAD SOLUTIONS



TOOLINGS FOR SLIDING HEAD MACHINE

BACK





KEMMER

HARTMETALLWERKZEUGE GmbH



Product Range : -

- PARTING | GROOVING
- TURNING ISO INSERTS & HOLDERS
- SPECIAL DESIGN CARBIDE TOOLS

Vidheksh
SLIDING HEAD SOLUTIONS



TOOLS FOR CNC TURNING MACHINE

BACK



HAHNREITER
GEWINDETECHNIK



Product Range : -

- STANTARD & SPECIAL TAPS
- STANTARD & SPECIAL DIES
- STANTARD & SPECIAL GAUGES

Vidheksh
SLIDING HEAD SOLUTIONS



THREADING SOLUTIONS

BACK





PCM

be driven.



- Rotary Broaching Tools
- Live Tools for CNC Swiss Automatics
- Accessories like Tapping Collets, ER Collet etc.
- Tool Holders for Hydromat Rotary Transfer Machines

PCM - SWISS SOLUTION



ASSOCIATE WITH

BACK



Vidheksh
SLIDING HEAD SOLUTIONS



- EXTERNAL TURNING / TREADING TOOLS
- INTERNAL BORING TOOLS
- MICRO DRILLS

WHIZCUT - SWISS TOOLING

BACK



ASSOCIATE WITH



Vidheksh
SLIDING HEAD SOLUTIONS



BURNISHING TOOLS



KNURLING TOOLS



KNURLS



BROACHING HEADS



BROACHES



TURNING TOOLS

INTEGI – KNURLING & BROACHING

BACK



ASSOCIATE WITH



Vidheksh
SLIDING HEAD SOLUTIONS

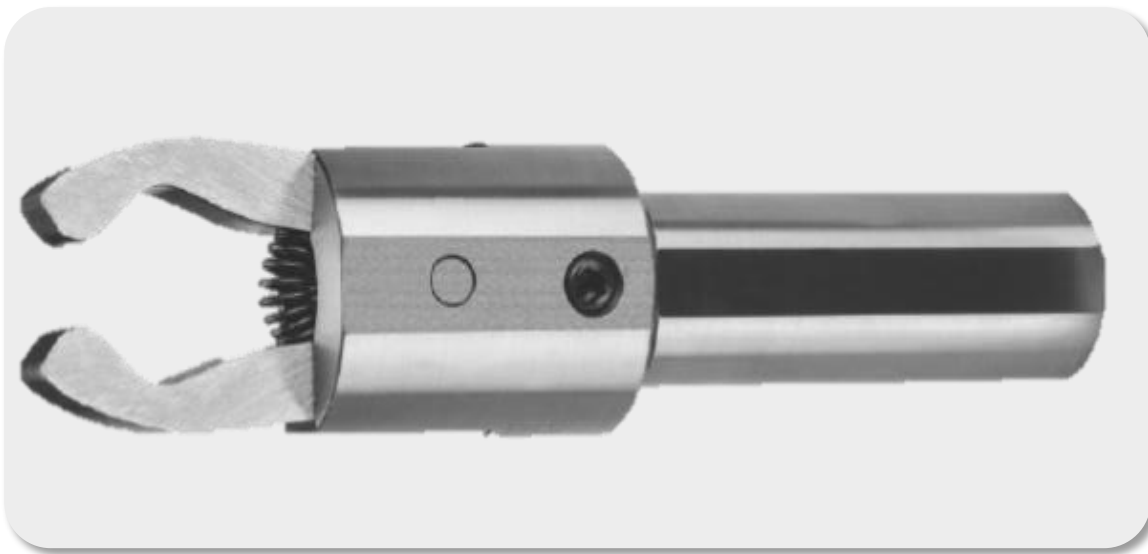

DIAMETER
RANGE
2MM TO 35MM

FOR CNC TURNING MACHINE

BAR PULLER ADVANTAGES

- Easy to setup and Easy to use.
- Freeing up operators to handle other tasks.
- Increase Productivity up to 20 to 30%
- Improve productivity by enabling CNC lathes to run unattended.
- Impeccable quality at reasonable prices.



CNC BAR PULLER



Vidheksh
SLIDING HEAD SOLUTIONS

C-131, Safal Sumel -7, Soni Ni Chawl, Rakhiyal, Ahmedabad - 380023
99796 86648 | 98799 86648 | solution@vidheksh.com | www.vidheksh.com



FOR OUTER
DIAMETER
CLAMPING

RANGE
A25
A42
A60

CNC COLLET CHUCK ADVANTAGES

- EASY AND FAST CHANGE-OVER.
- INCREASED GRIPPING RANGE.
- ACCURACY AND RIGIDITY.
- REDUCE MAINTENANCE.
- IMPECCABLE QUALITY AT REASONABLE PRICES.

CNC COLLET – OD CLAMPING



Vidheksh
SLIDING HEAD SOLUTIONS

C-131, Safal Sumel -7, Soni Ni Chawl, Rakhiyal, Ahmedabad - 380023
99796 86648 | 98799 86648 | solution@vidheksh.com | www.vidheksh.com



FOR INSIDE
DIAMETER
CLAMPING

RANGE
20-45MM
46-70MM

CNC COLLET CHUCK ADVANTAGES

- EASY AND FAST CHANGE-OVER.
- INCREASED GRIPPING RANGE.
- ACCURACY AND RIGIDITY.
- REDUCE MAINTENANCE.
- IMPECCABLE QUALITY AT REASONABLE PRICES.

CNC COLLET – ID CLAMPING



Vidheksh
SLIDING HEAD SOLUTIONS

C-131, Safal Sumel -7, Soni Ni Chawl, Rakhiyal, Ahmedabad - 380023
99796 86648 | 98799 86648 | solution@vidheksh.com | www.vidheksh.com



FOR LATHE /
MILLING /
DRILLING
MACHINE

UNIVERSAL MANUAL COLLET CHUCK

- EASY AND FAST CHANGE-OVER FOR MILLING / DRILLING / LATHE MACHINE.
- INCREASED GRIPPING RANGE.
- ACCURACY AND RIGIDITY.
- REDUCE MAINTENANCE.
- IMPECCABLE QUALITY AT REASONABLE PRICES.

UNIVERSAL COLLET CHUCK



Vidheksh
SLIDING HEAD SOLUTIONS

C-131, Safal Sumel -7, Soni Ni Chawl, Rakhiyal, Ahmedabad - 380023
99796 86648 | 98799 86648 | solution@vidheksh.com | www.vidheksh.com

MACHINE SPARES



APC BATTERY 6V



FANUC FAN



MPG BOX



MPG WHEEL



FANUC FUSE



FANUC FUSE



PUSH BUTTON SWITCH



LED CNC LIGHT TOWER LAMP



CNC DISPLAY



CNC KEYPAD SOFT KEYS



ROTARY KNOBS



ROTARY KNOBS



ENCODER



PROXIMITY SENSORS



RELAYS-OMRON



RELAYS



ALLIED CONNECTORS



FLAT CABLE



OPTICAL CABLE



CABLE DRAG CHAIN



POWER FEEDBACK CABLE



LAPP CABLE



LAPP CABLE



ROTARY SWITCHES



ROTARY SWITCHES



SPINDLE MOTOR
COOLING FAN



COOLING FANS



PUMP POWER SUPPLY
SMPS



COOLANT PUMP MOTOR



IMPELLER FOR
COOLANT PUMP



PRESSURE SWITCH



AC MESH FILTERS



FILTERS AND ELEMENTS



BALL SCREW



LM GUIDEWAYS



BELLOWS



FOOT SWITCHES



DRAWBAR DISK SPRING



TURRET MOTOR



TURRET



HYDRAULIC CHUCK
& JAWS



METERING CARTRIDGE



LUBRICATION SYSTEM



KLUBER ISOFLEX GREASE



DEUBLIN ROTARY
UNIONS



PISTON P-80



TURCITE



FRL UNITS



PNEUMATIC PARTS



HYDRAULIC CYLINDER
WITH VALVE



HYDRAULIC POWER PACK



STABILIZER
TRANSFORMER



BEARINGS
(NSK - SKF - FAG - RHP
- INDIAN - CHINA ETC...)



CYLINDER
PISTON SEAL SET-O RINGS



TIMING BELTS AND
MACHINE BELTS

**PLEASE CONTACT
US FOR FURTHER
ASSISTANCE**

THANK YOU

VIRAL MEHTA

99796 86648

98799 86648